

ICE 8RFB Vibratory Hammer

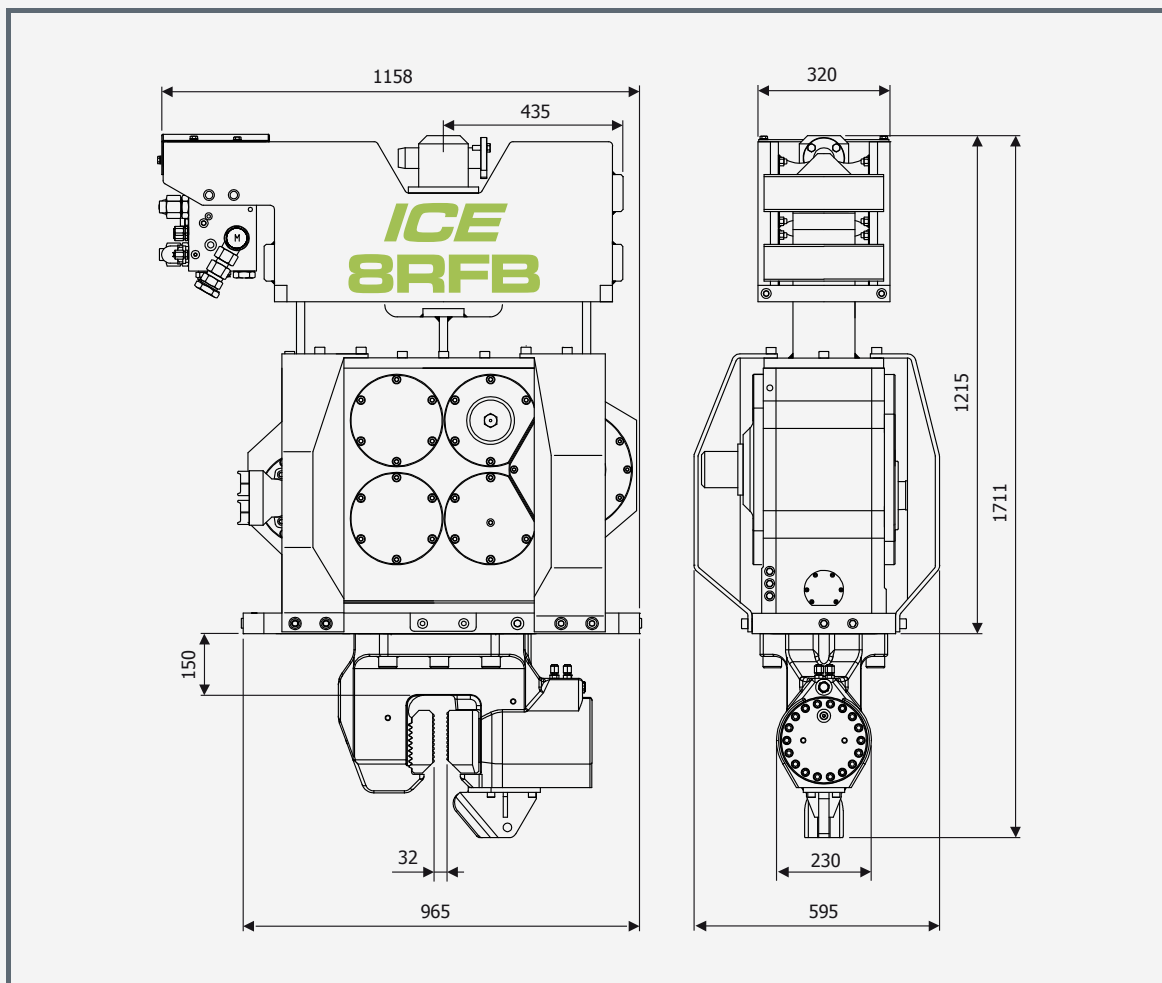

Specifications		8RFB	Clamps:
Eccentric moment	0 – 7.5	kgm	Sheet pile clamp
Max. centrifugal force	0 – 435	kN	60TU
Max. frequency	2300	rpm	Transport weight per piece
Max. amplitude excluding 60TU	15.2	mm	250
Max. amplitude including 60TU	12.1	mm	kg
Max. static line-pull	120	kN	
Max. hydraulic power	108/147	kW/HP	
Max. operating pressure	350	bar	
Max. oil flow	185	l/min	
Forced lubrication	Yes		
Dynamic weight excluding 60TU	985	kg	
Dynamic weight including 60TU	1235	kg	
Total weight including 60TU	1515	kg	